

High power type Capacitors

GREEN CAP 70°C Low ESR 2.5V / 2.7V

- Low internal resistance allows boosting charge and heavy-current discharge. (ampere level)
- Pollution-Free ; with no pollutants such as Cd or Pb.
- Unlimited number of charges and discharges.

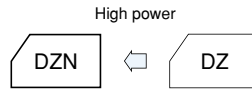

Marking color : White print on a blue sleeve

Specifications

Item	Performance									
Category temperature range (°C)	-25 to +70									
Tolerance at rated capacitance (%)	-20 to +80									
Internal resistance at 1 kHz	Rated Capacitance (F)	0.7	1.0	3.3	4.7	10	20	50	100	
	Internal resistance (Ω)	0.4	0.3	0.2	0.10	0.10	0.10	0.03	0.03	
Characteristics at high and low temperature	Percentage of capacitance change	Within ±30% of value at 20°C								
	Internal resistance	Less than five times of the value at 20°C								
Endurance (70°C)	Test time	1000 hours								
	Percentage of capacitance change	Within ±30% of the initial measured value								
	Internal resistance	Within four times of the initial specified value								
Shelf life (70°C)	Test time : 1000 hours ; Same as endurance.									

Outline Drawing

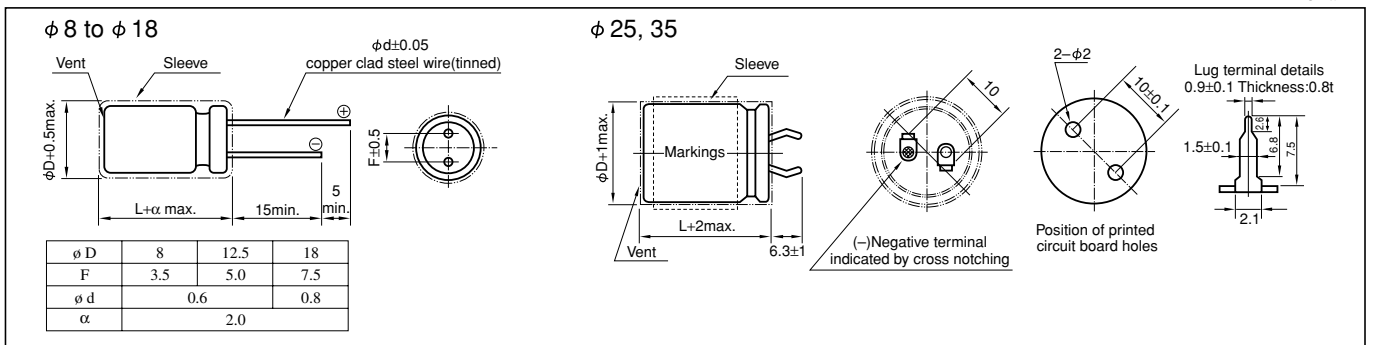

Standard Ratings (2.5V)

Max. operating voltage(V)	Rated capacitance(F)	Max. Leakage Current(mA) after 24h	ELNA Parts No.	φ DxL(mm)	Internal resistance(mΩ) at 1kHz (measurement value)
2.5	0.7	0.1	DZN-2R5D704G4T	8.0x15.0	200
2.5	1.0	0.1	DZN-2R5D105T	8.0x22.0	100
2.5	3.3	0.2	DZN-2R5D335T	12.5x23.0	40
2.5	4.7	0.3	DZN-2R5D475T	12.5x31.5	30
2.5	10	0.5	DZN-2R5D106T	18.0x35.0	20
2.5	20	0.8	DZN-2R5D206T	18.0x40.0	20
2.5	50	1.0	DZN-2R5D506T	25.0x40.0	15
2.5	100	1.0	DZN-2R5D107T	35.0x50.0	8

Standard Ratings (2.7V)

Max. operating voltage(V)	Rated capacitance(F)	Max. Leakage Current(mA) after 24h	ELNA Parts No.	φ DxL(mm)	Internal resistance(mΩ) at 1kHz (measurement value)
2.7	1.0	0.2	DZN-2R7D105G5T	8.0x22.0	120
2.7	3.3	0.3	DZN-2R7D335Z6T	12.5x23.0	50
2.7	4.7	0.4	DZN-2R7D475Z7T	12.5x31.5	40
2.7	10	0.6	DZN-2R7D106K8T	18.0x35.0	20
2.7	20	1.0	DZN-2R7D206K9T	18.0x40.0	20

* Internal resistance are not guaranteed values, but measurement value.
 * We tailor packaged product in series and parallel arrangements according to voltage and capacitance as required.

Part numbering system (example: 2.5V10F)

